

## Welded - Assembled "Contempra" Rack Cabinets (C2RR Series) - *Rapid Rack*

Path: [Home](#) > [Rack Index](#) > Welded - Assembled - *Rapid Rack* Cabinets (C2RR Series)



### Features:

- Heavy duty - welded rack (1,500 lb even load rating)...
- Standard 19" panel width (23" overall)...
- Choice of two stock depths:
  1. usable depth of 21.63" (23.63" overall)
  2. usable depth of 29.50" (31.50" overall)
- Unit is shipped complete (NO ASSEMBLY REQUIRED) with removable side panels (1/4 turn latches), 4 infinitely adjustable - combination rack mount rails (Full EIA hole centers - 5/8 - 5/8 - 1/2 inch spacing), one solid flush mount door, solid top and 4 leveling feet...
- Heavy duty: 14 gauge steel frame, 16 gauge side panels.
- Rails are made of 10 gauge zinc plated steel...
- Recommended maximum weight (C2F247836 tested) - 1,500 pounds...
- Finished in a rugged, textured powder paint finish...
- See frame [accessories below](#).

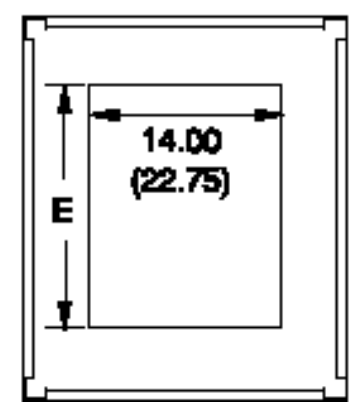
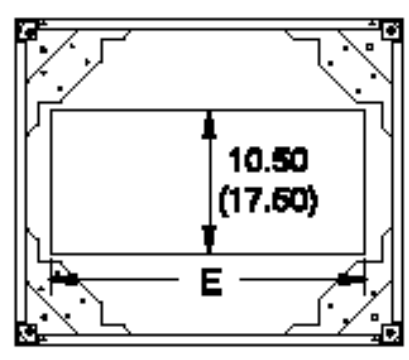
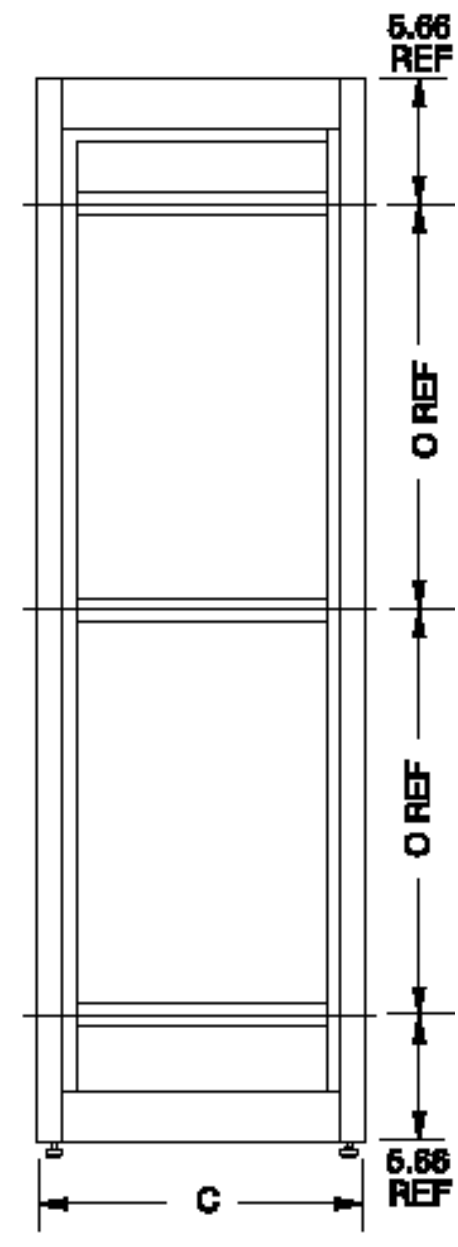
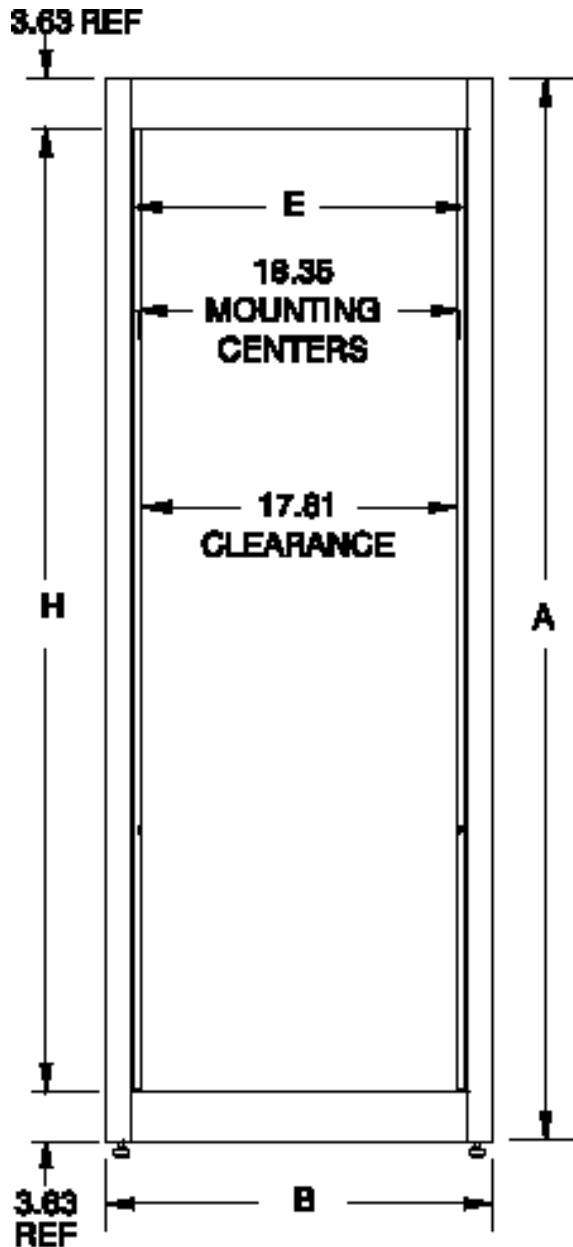

**23.63" Deep models:**  
Usable Depth = 21.63"

Part Number	Color	Drawing File Size	AutoCAD .dxf File (zipped)	.zip File Size	Panel Height		Overall Dimensions				Wt. lbs.
					Inches	Units	A	B	C	H	
<b>C2RR194223BK1</b> <b>C2RR194223CG1</b>	Black Gray/ Beige	68K		52K	<b>42</b>	24	49.31	23	23.63	42.06	205
<b>C2RR196323BK1</b> <b>C2RR196323CG1</b>	Black Gray/ Beige	68K		52K	<b>63</b>	36	70.31	23	23.63	63.06	260
<b>C2RR197023BK1</b> <b>C2RR197023CG1</b>	Black Gray/ Beige	68K		52K	<b>70</b>	40	77.31	23	23.63	70.06	295
<b>C2RR197823BK1</b> <b>C2RR197823CG1</b>	Black Gray/ Beige	68K		52K	<b>78.75</b>	45	86.06	23	23.63	78.81	330

**31.5" Deep models:**

Usable Depth = 29.50"

Part Number	Color	Drawing File Size	AutoCAD .dxf File (zipped)	.zip File Size	Panel Height		Overall Dimensions				Wt. lbs.
					Inches	Units	A	B	C	H	
<b>C2RR194231BK1</b> <b>C2RR194231CG1</b>	Black Gray/ Beige	68K		52K	<b>42</b>	24	49.31	23	31.5	42.06	218
<b>C2RR196331BK1</b> <b>C2RR196331CG1</b>	Black Gray/ Beige	68K		52K	<b>63</b>	36	70.31	23	31.5	63.06	280
<b>C2RR197031BK1</b> <b>C2RR197031CG1</b>	Black Gray/ Beige	68K		52K	<b>70</b>	40	77.31	23	31.5	70.06	315
<b>C2RR197831BK1</b> <b>C2RR197831CG1</b>	Black Gray/ Beige	68K		52K	<b>78.75</b>	45	86.06	23	31.5	78.81	355



PART No. C2RR194223

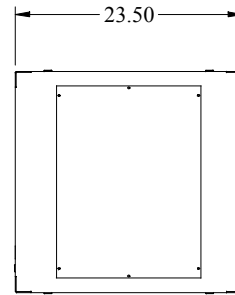
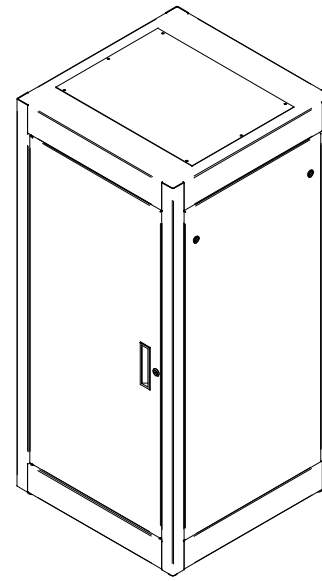

TOP VIEW

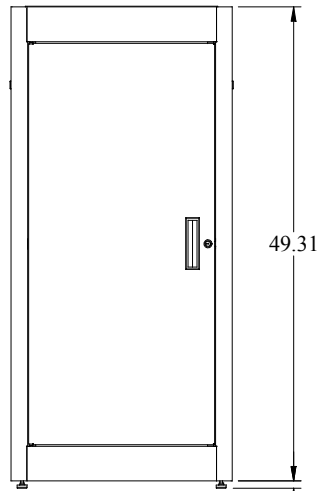

FRONT VIEW

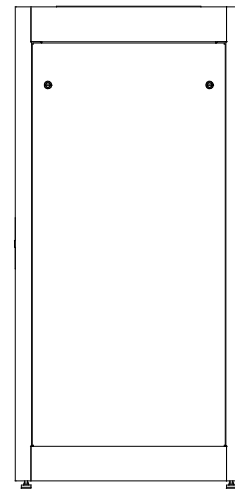

RIGHT SIDE VIEW

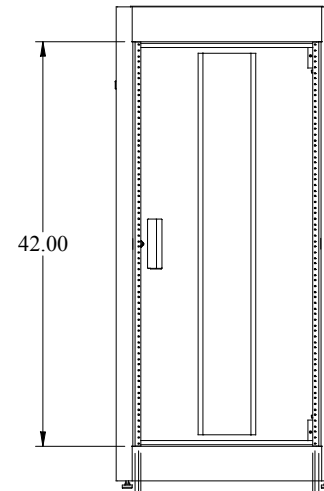

BACK VIEW

.77  
REF

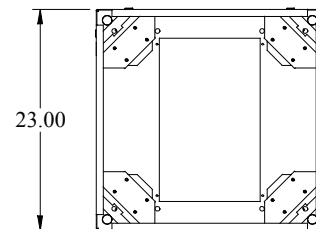

BOTTOM VIEW

# General Purpose - Rapid Rack (C2RR Series)



**RAPID RACK  
POPULAR CONFIGURATIONS**

## FEATURES

- Unit is shipped complete (**NO ASSEMBLY REQUIRED**)
- Choice of two depths 23.6" or 31.5" (21.63 or 29.5 usable depth)
- Heavy duty - Recommended maximum weight (C2F247836 tested) - 1,500 pounds
- Standard 19" panel width (23" overall width)
- **Unit includes:**
  - two removable side panels (with 1/4 turn latches)
  - four infinitely adjustable, tapped combination rack mount rails (full E.I.A. spacing)
  - one solid flush mount door (can be either front or back as rack is symmetrical) - locking with 2 keys
  - solid top
  - four leveling feet
- Heavy duty 14 gauge steel frame
- Formed 16 gauge steel side panels are recessed to fit flush with the sides of the cabinet
- Welded corner reinforcements
- Opening in bottom for cable entry
- Panel rails are zinc plated, 10 gauge steel, drilled and tapped 10-32
- Finished in a rugged, textured powder paint



**ASSEMBLED**  
*Shipped on its own skid  
for handling ease &  
protection  
**FROM STOCK!***

Assembled

Welded

# General Purpose - Rapid Rack (C2RR Series)

Front View

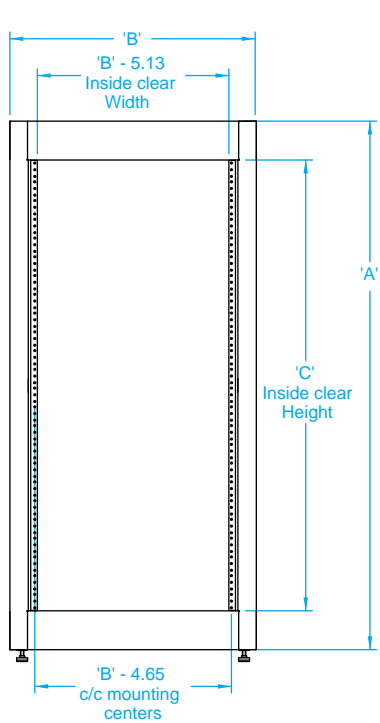

Side View  
(Side Panel  
Not Shown)

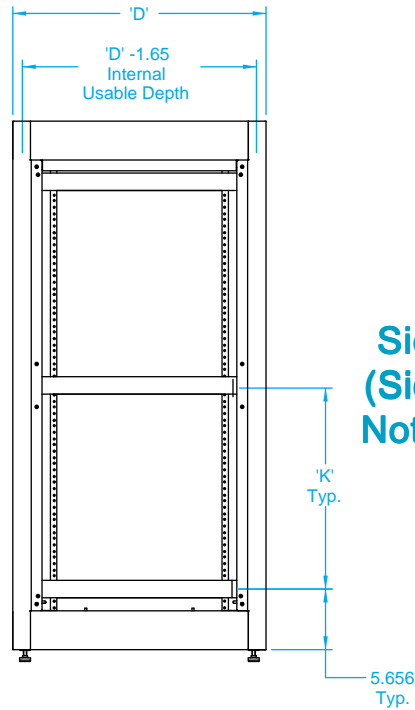

Bottom View

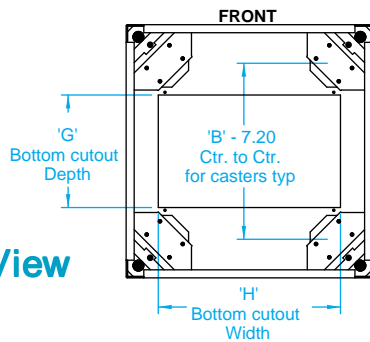

Top View  
(Top Cover  
Not Shown)

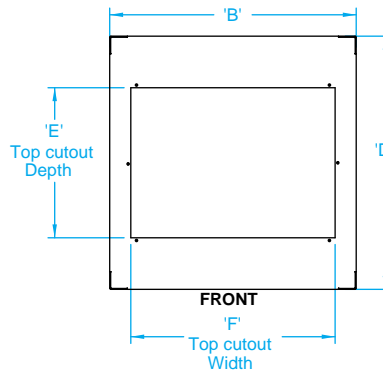

23.63" Deep (Usable Depth = 21.63")

Part Number		Dimensions (Inches)									
		Panel Height		Overall			Top Cutout		Bottom Cutout		Strut Spacing
				Height	Width	Depth	Depth	Width	Depth	Width	
Black Textured	Beige Textured	C	Units	A	B	D	E	F	G	H	K
C2RR194223BK1	C2RR194223CG1	42.06	24	49.31	23	23.63	14	19	10.5	17	19.00
C2RR196323BK1	C2RR196323CG1	63.06	36	70.31	23	23.63	14	19	10.5	17	29.50
C2RR197023BK1	C2RR197023CG1	70.06	40	77.31	23	23.63	14	19	10.5	17	33.00
C2RR197823BK1	C2RR197823CG1	78.81	45	86.06	23	23.63	14	19	10.5	17	37.38

31.5" Deep (Usable Depth = 29.5")

Part Number		Dimensions (Inches)									
		Panel Height		Overall			Top Cutout		Bottom Cutout		Strut Spacing
				Height	Width	Depth	Depth	Width	Depth	Width	
Black Textured	Beige Textured	C	Units	A	B	D	E	F	G	H	K
C2RR194231BK1	C2RR194231CG1	42.06	24	49.31	23	31.50	22.75	19	17.5	17	19.00
C2RR196331BK1	C2RR196331CG1	63.06	36	70.31	23	31.50	22.75	19	17.5	17	29.50
C2RR197031BK1	C2RR197031CG1	70.06	40	77.31	23	31.50	22.75	19	17.5	17	33.00
C2RR197831BK1	C2RR197831CG1	78.81	45	86.06	23	31.50	22.75	19	17.5	17	37.38

Assembled

Welded

